

F

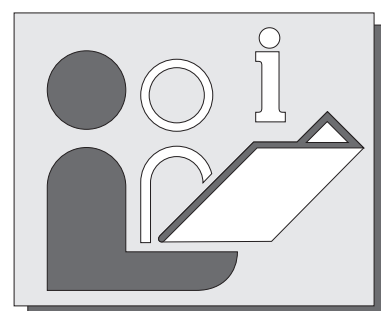







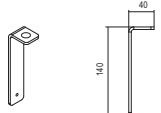
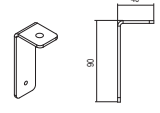
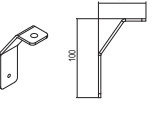
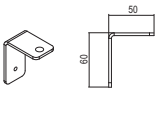

Notice de montage

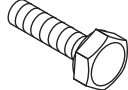

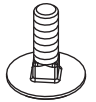





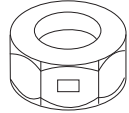
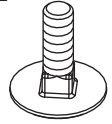

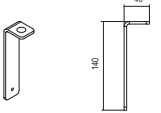
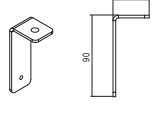
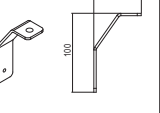
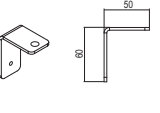

464 462
a b c d e f
2008

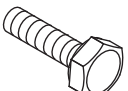

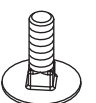
Autoportées 92

464327  1x	464328  1x	464329  1x	464430  1x	464431  2x
700854 Ressort plat  1x	704383 M8x22  2x	464432  2x	464498 M5x16  11x	704138 M6x16  3x
705657 M6  1x	700147  11x	704538  2x	700128  2x	512725  1x
348988 M8 assuré  6x	702632 M10x25  4x			

Autoportées 102

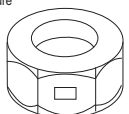
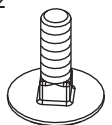
464327  1x	464328  1x	464329  1x	464430  1x	464431  2x
700854 Ressort plat  1x	704383 M8x22  2x	464432  2x	464498 M5x16  8x	703484 M5x16  7x
705656 M5  7x	700147  8x	704538  2x	700128  2x	512725  1x
348988 M8 assuré  6x	702632 M10x25  4x			

464462

hydro

1

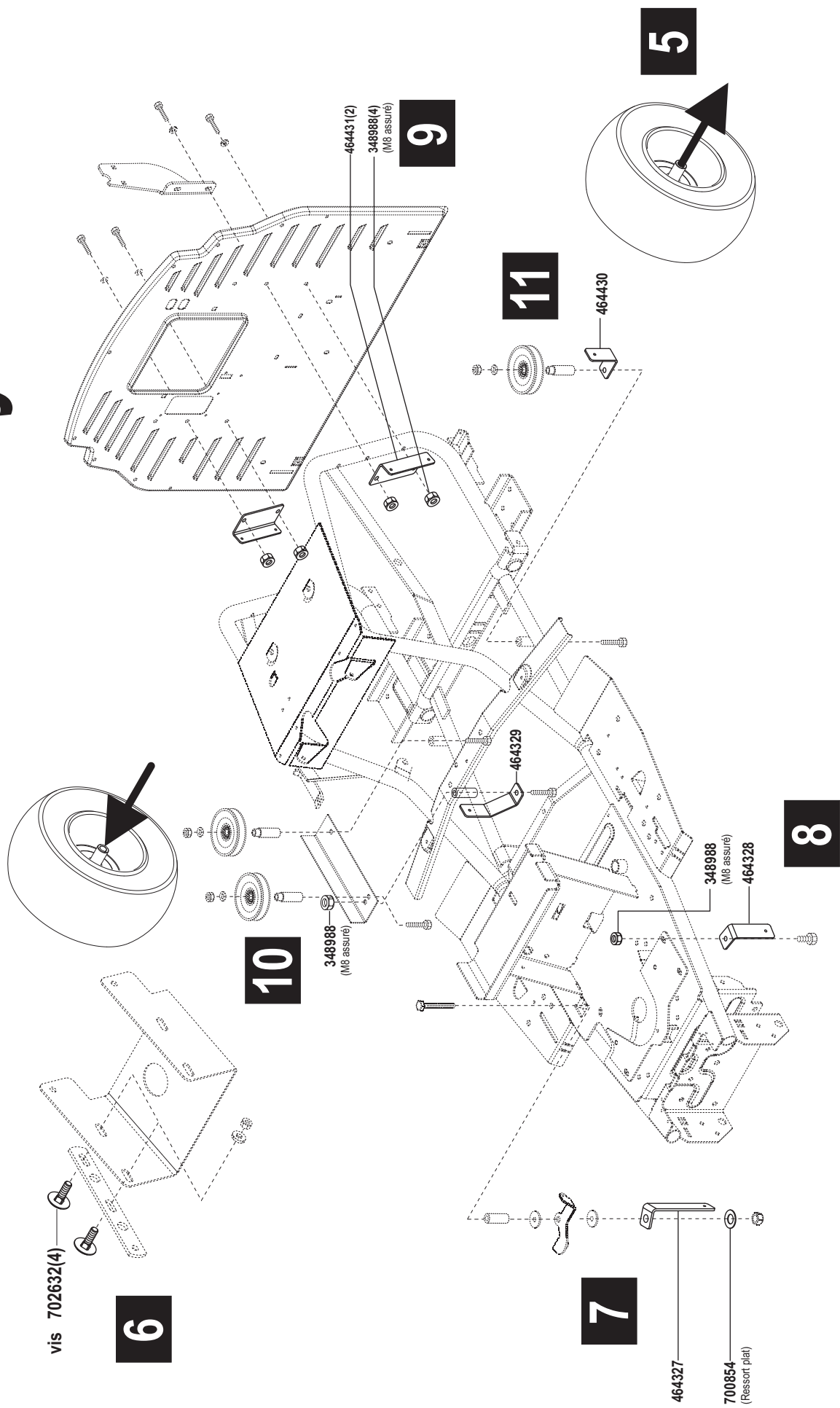

1 5 vitesses

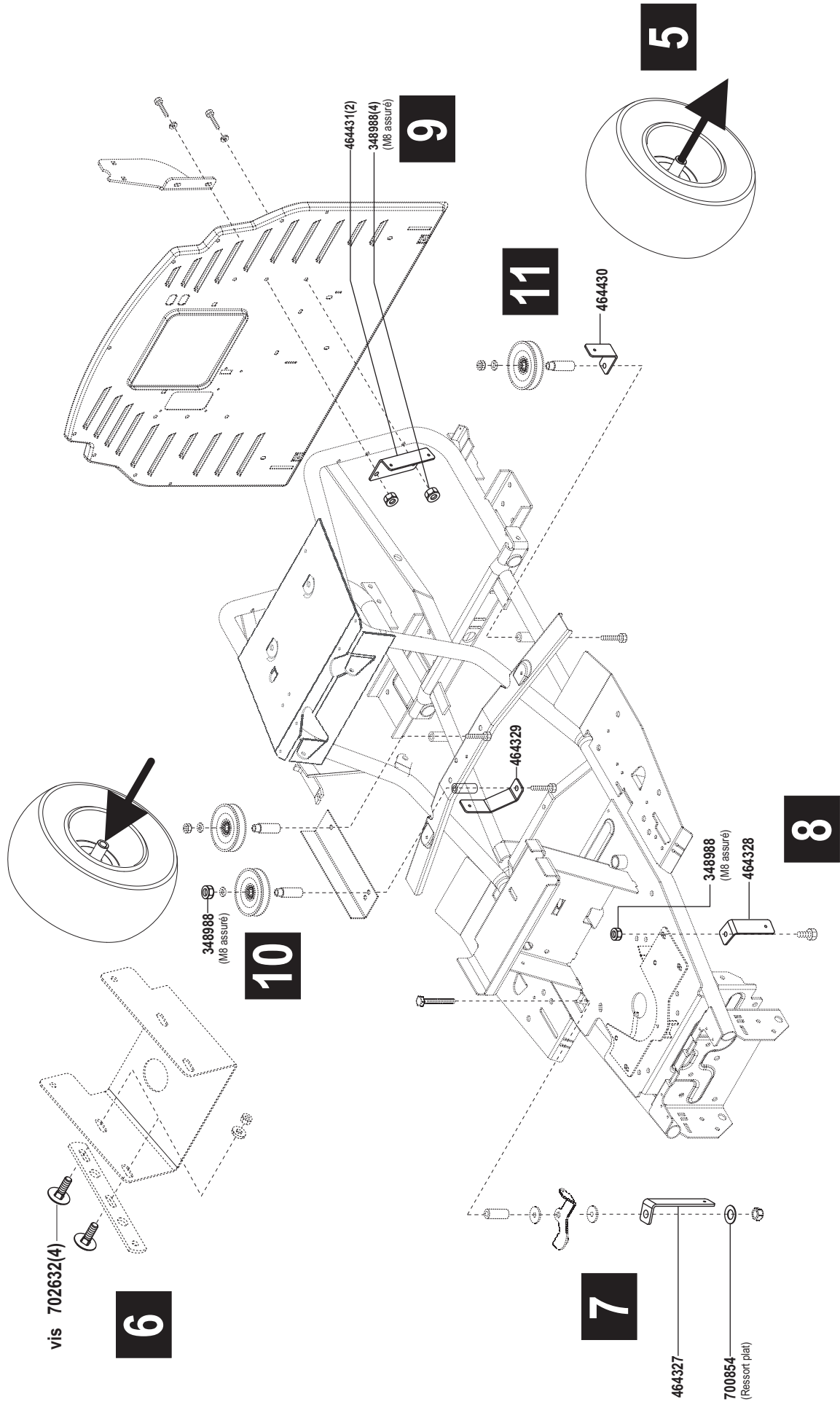

2

5 vitesses und hydrostatique manuel

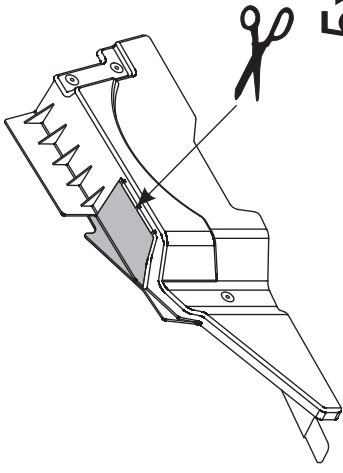

5X

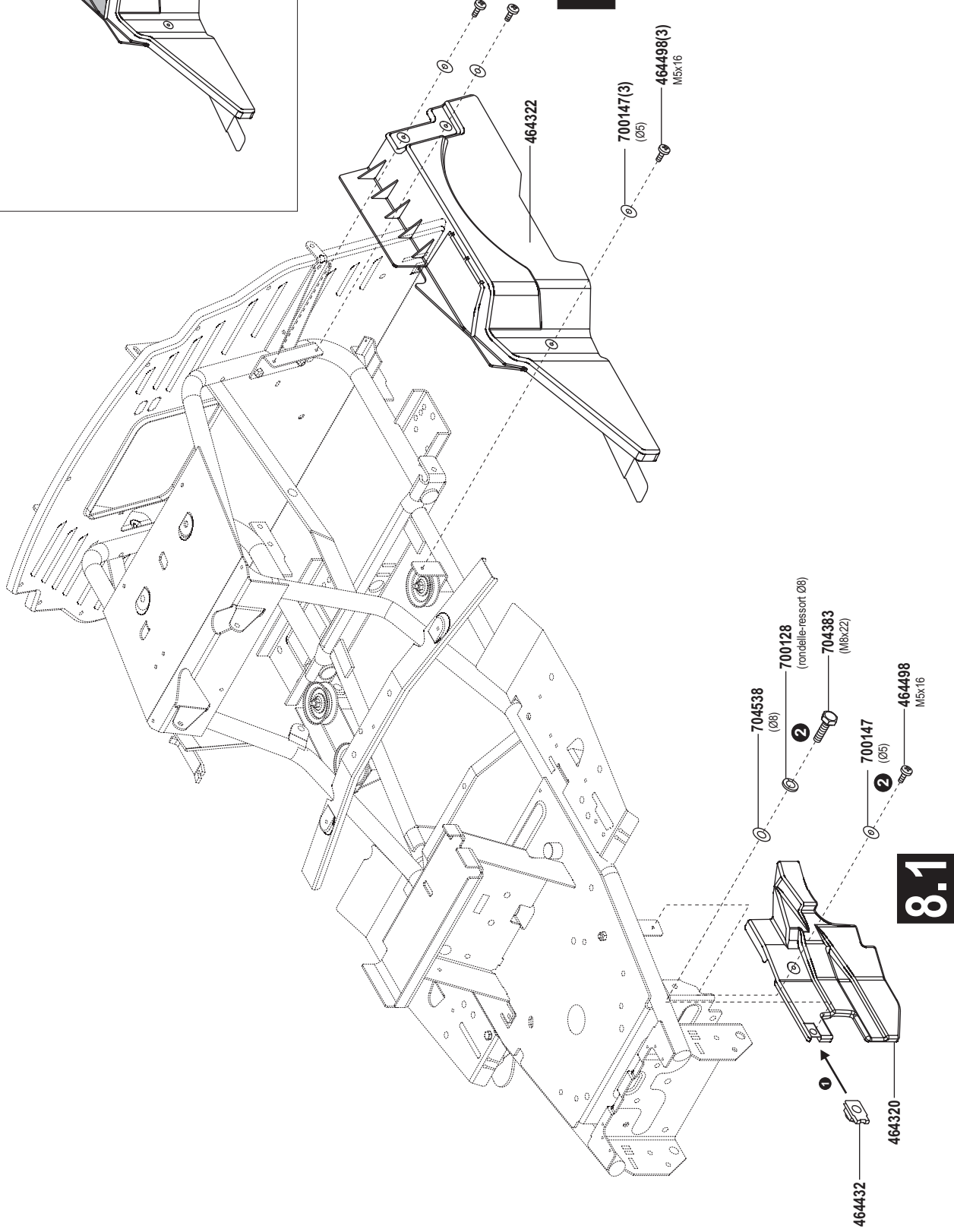

3

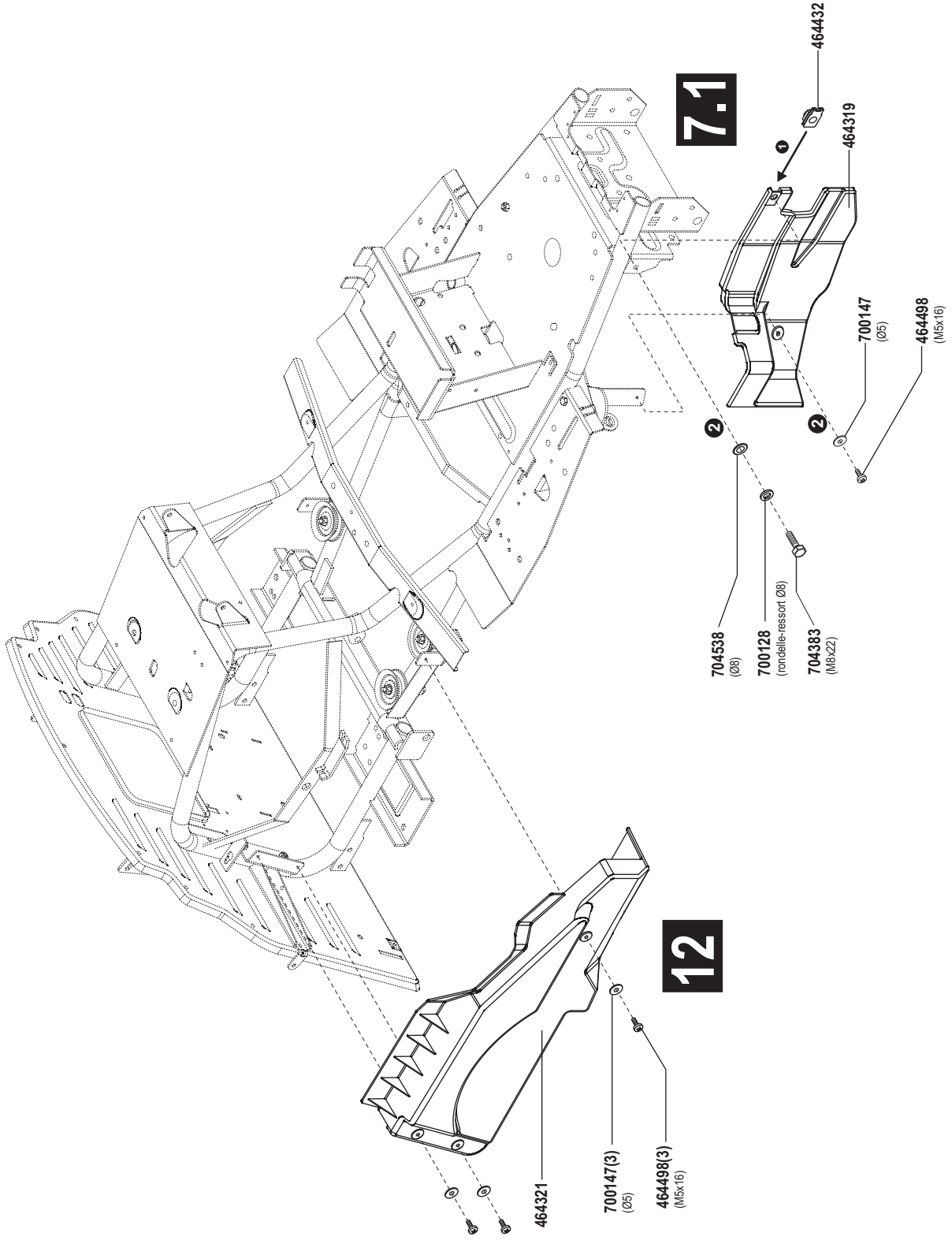

hydrostatique à pied

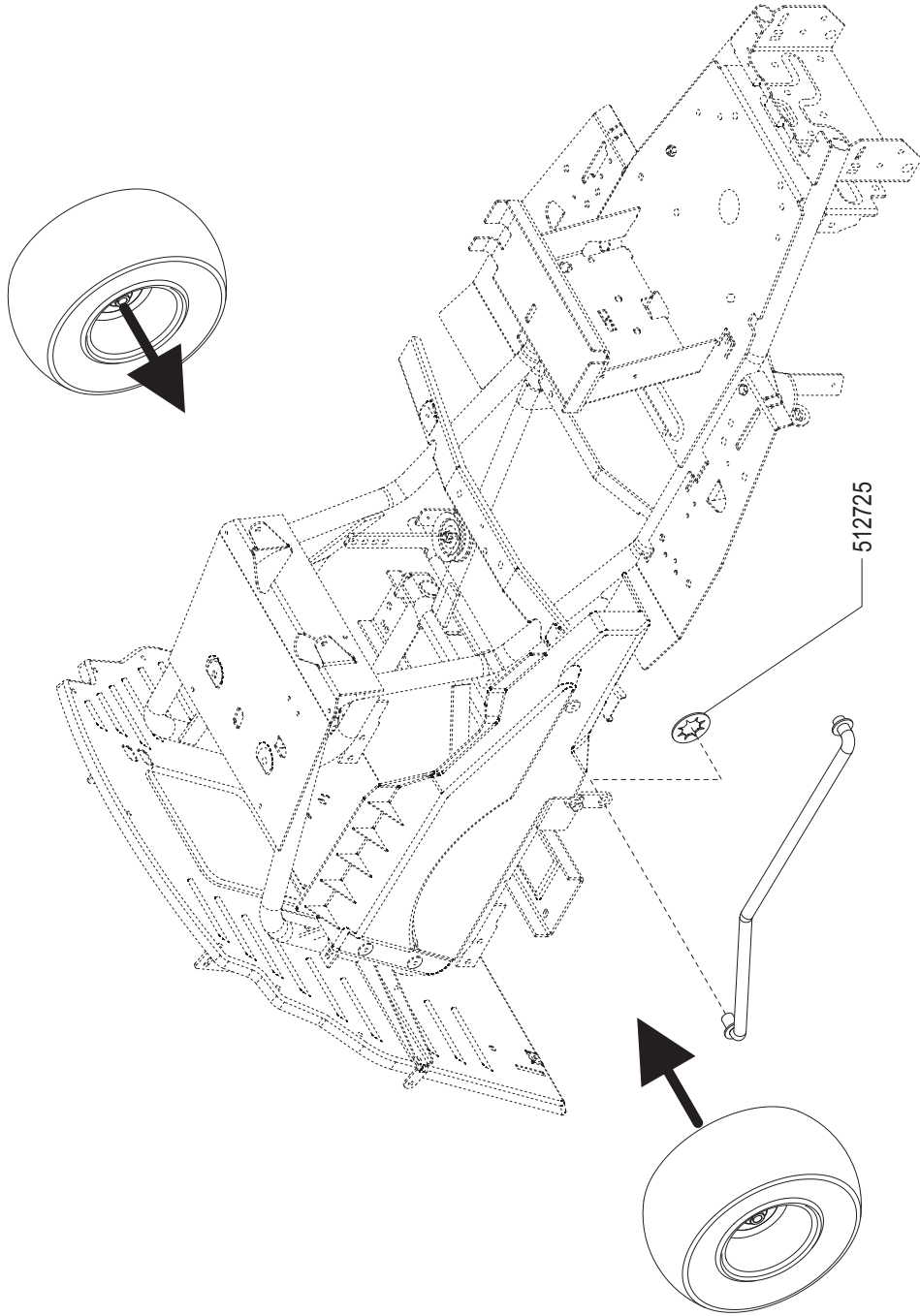

4 système de coupe 92 cm

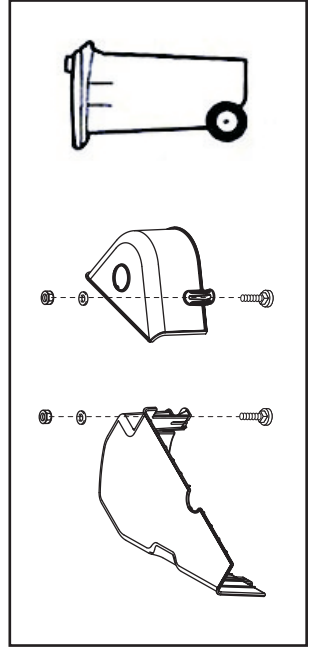
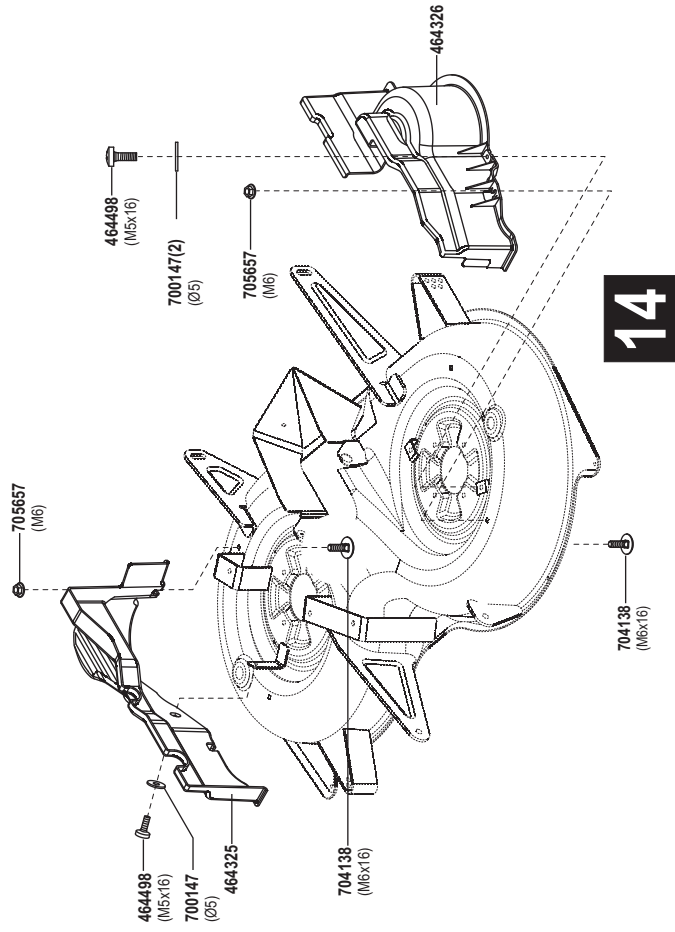
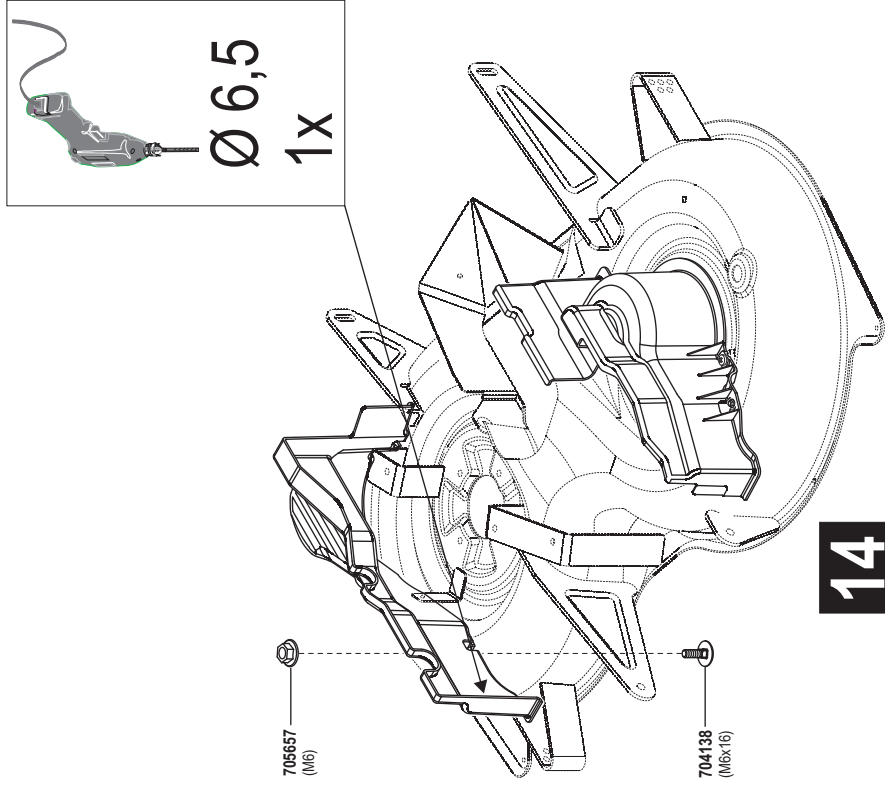

4 système de coupe 102 cm

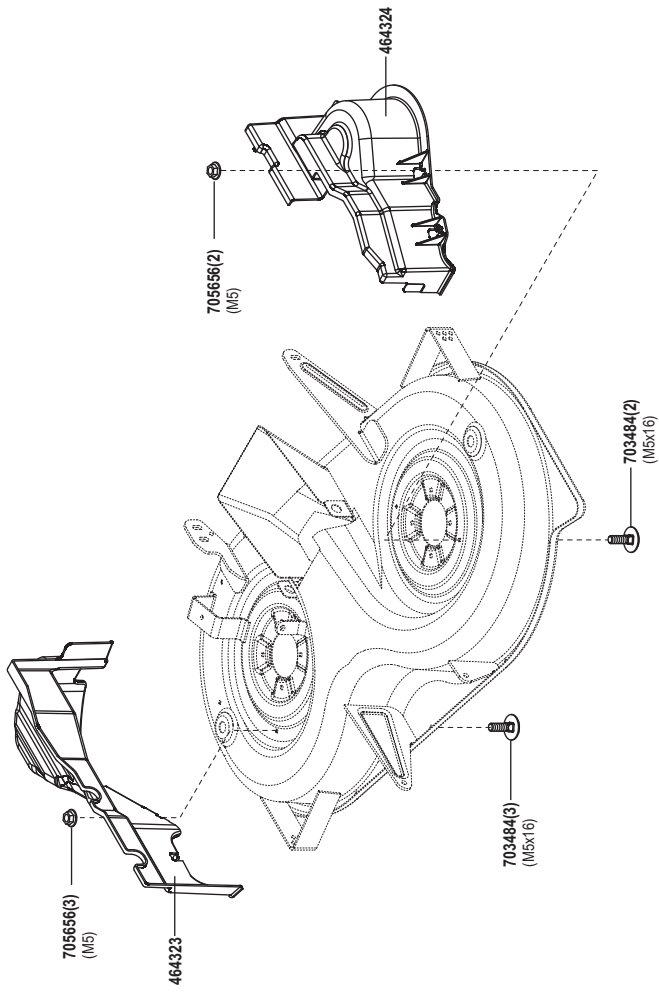
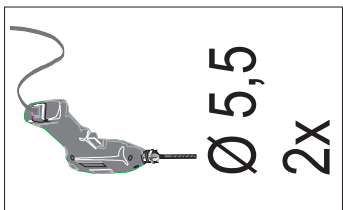

14

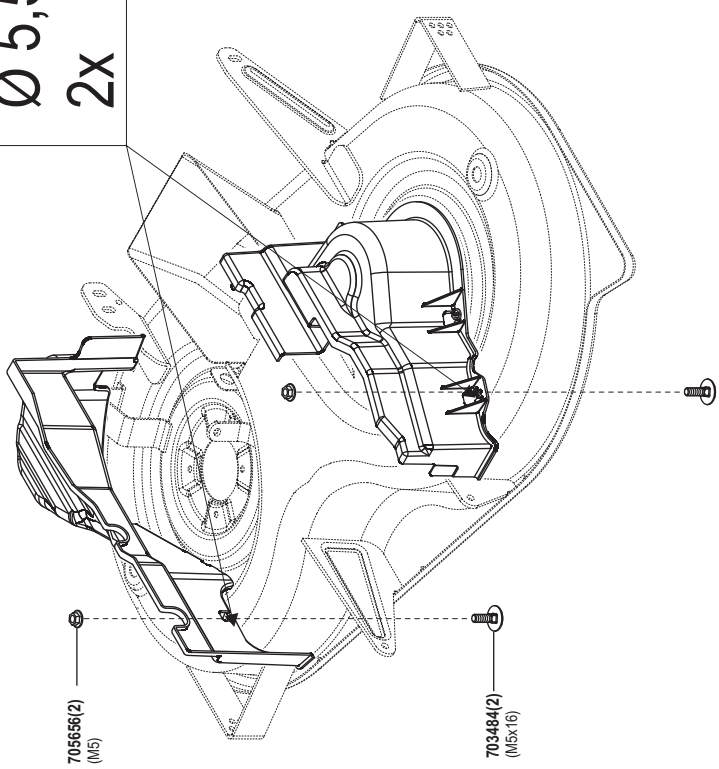
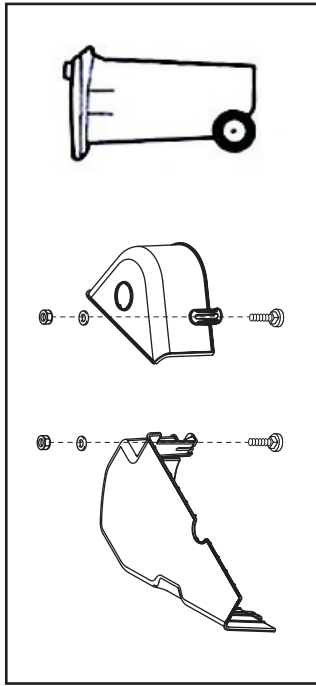

14

Notice de montage

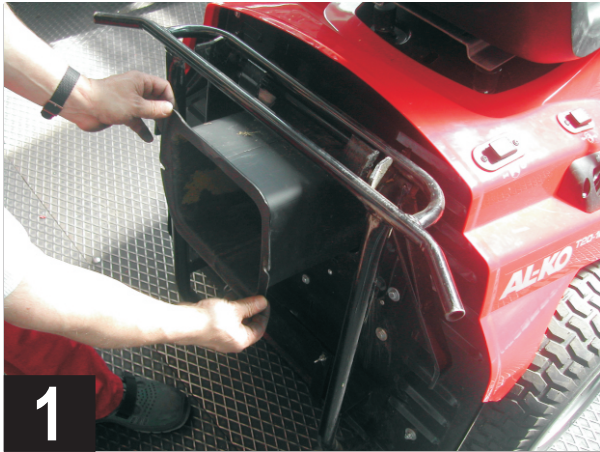

Démontage canal d'éjection

Dévisser vis hexagonales (SW 10) puis enlever avec les rondelles plates.

Tirer canal d'éjection à travers le panneau arrière.



Démontage Capot

Appuyer sur le capot du moteur en direction du volant et le soulever simultanément.

Ouvert, tourner le capot légèrement vers l'arrière puis lever vers le haut.



Mettre appareil en position relevée.
(avec accessoire de relevage)



Démontage système de coupe

1. Tirer goupille fendue de l'axe avant.

2. Sortir axe.

Notice de montage

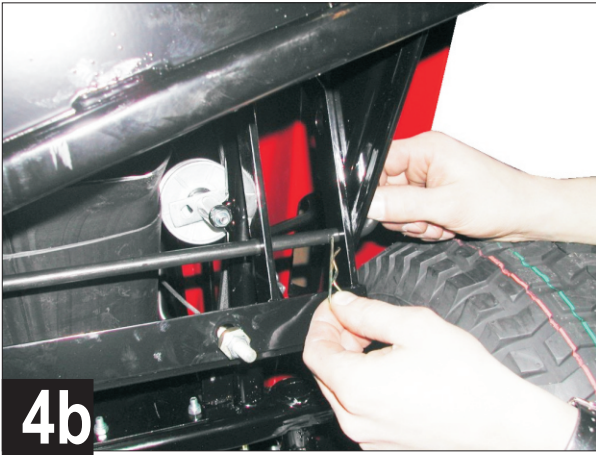

1. Tirer goupille fendue de l'axe arrière.
2. Sortir axe.



1. Fixer suspension du système de coupe (devant vers le haut (cordes, câbles, etc.)
2. Positionner les roues avant, selon illustration.



1. Soulever légèrement système de coupe.
2. Lever courroie trapézoïdale de la poulie à gorge, et déposer système de coupe sur un fond convenable.

Notice de montage



Démonter roues arrière

(si machine en carton, tirer simplement les roues:
Attention de ne pas perdre la clavette)

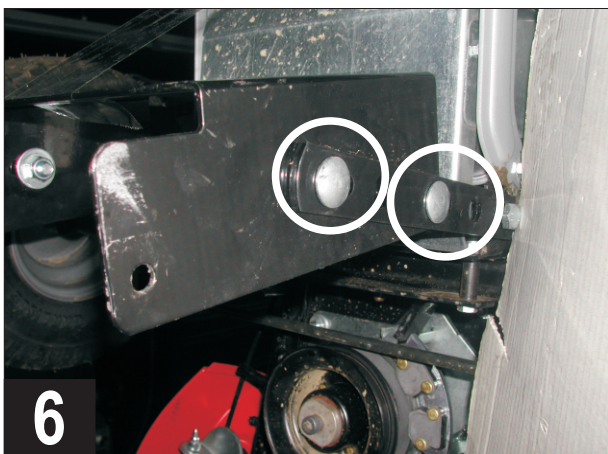

Changer les vis du support plateau.

Attention: Changer en vis par vis afin
de serrer du conserver la position véritable du support.

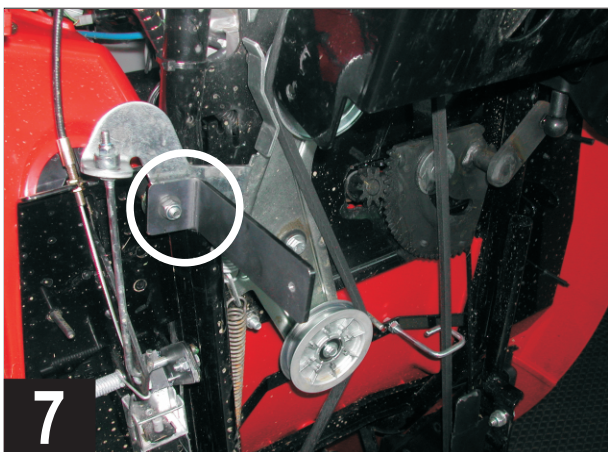

Équerre monté comme indiqué.
Utiliser la vis distante

Matériel de fixation voir page 2 et 3.

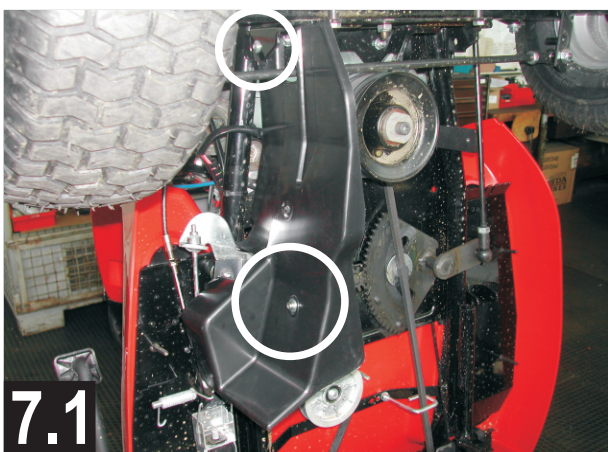

Carter plastique monté comme indiqué.

Matériel de fixation voir page 5.

Notice de montage

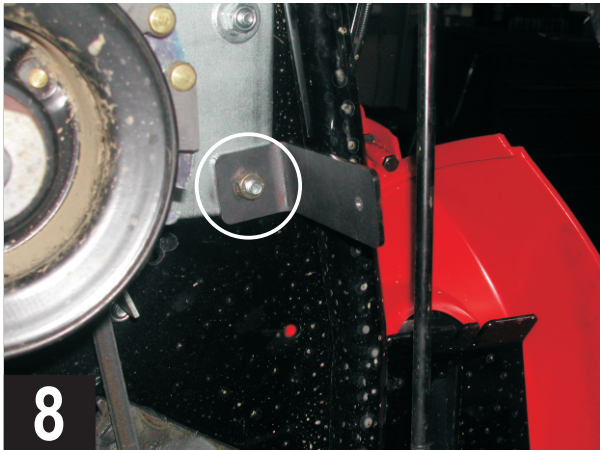

Équerre avant gauche monté comme indiqué.

Matériel de fixation voir page 2 et 3.



Carter plastique monté comme indiqué.

Matériel de fixation voir page 4.

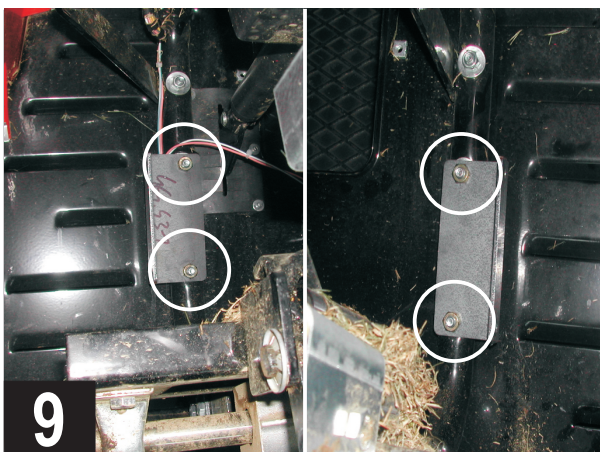

Motrer équerres droite et gauche à l'arrière sur le chassis.

Matériel de fixation voir page 2 et 3.

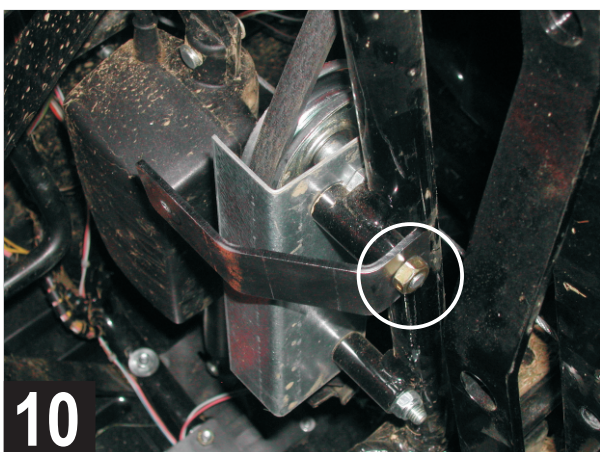

Monter équerre droite comme illustré (poulies doivent être démontées - changer ecron frain)

Matériel de fixation voir page 2 et 3.

Notice de montage

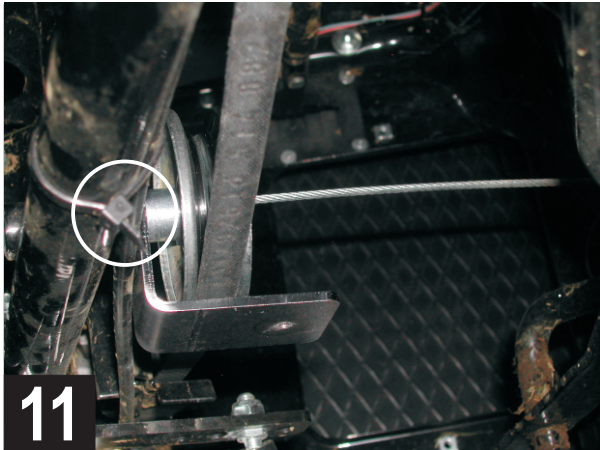

Monter équerre gauche comme illustré.

Matériel de fixation voir page 2 et 3

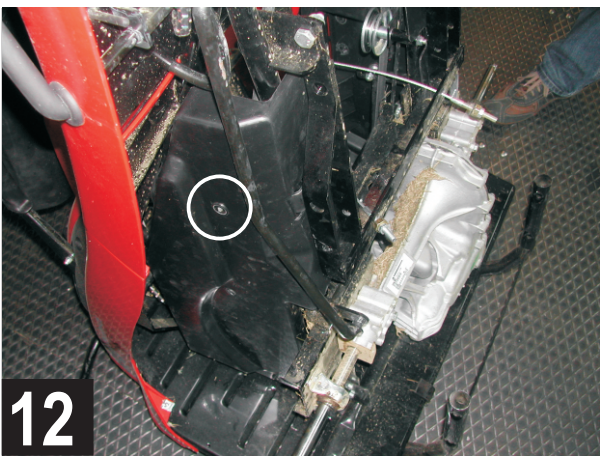

Monter carter plastique arrière droit.

Matériel de fixation voir page 5.

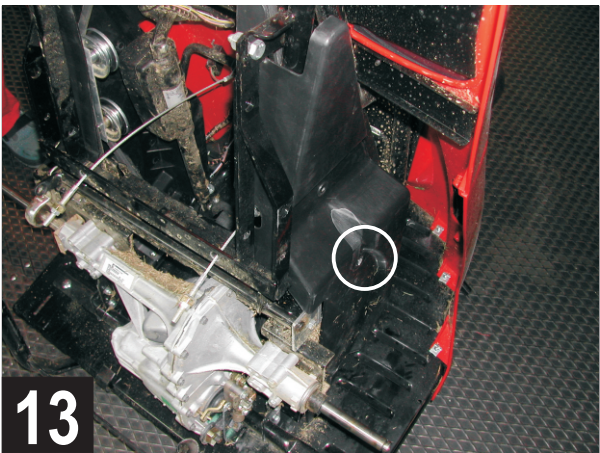

Monter carter plastique arrière gauche.

Matériel de fixation voir page 4.

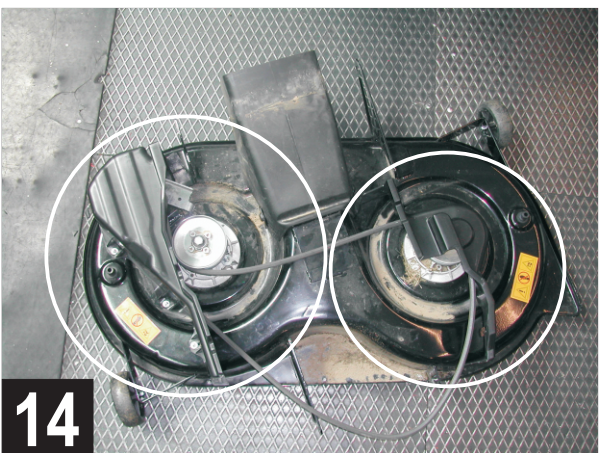

Monter carter plastiques comme illustré sur système de coupe.

Percer 1 trou pour montage de la 3ieme - vis (sur carter droit).

Matériel de fixation voir page 7 et 8.

- Remonter système de coupe .
- Remonter roues arrières (Attention à la clavette).